

Research of aerodynamics characteristics of wind power plant blades

M. Galdikas*, A. Vilkauskas**

*Kaunas University of Technology, Kęstučio 27, 44312 Kaunas, Lithuania, E-mail: mantas.galdikas@stud.ktu.lt

**Kaunas University of Technology, Kęstučio 27, 44312 Kaunas, Lithuania, E-mail: andrius.vilkauskas@ktu.lt

crossref <http://dx.doi.org/10.5755/j01.mech.19.3.4666>

1. Introduction

Nowadays a great deal of attention is paid to development and wide practical application of renewable energy sources. Wind energy is one of the most developed renewable energy spheres. Recently, vertical axis wind turbines because of their characteristics (low noise and bird friendly) are increasingly occupying a bigger part of the market in comparison to traditional horizontal axis wind turbines. Worldwide is known mostly popular horizontal axis power plants (HAWT), but lately vertical axis wind power plants (VAWT) are becoming more popular, because they have a lot of advantages such as low noise, more environmentally friendly and etc. [1]

This study examined the main types of wind power plants. Using flow designing fluid simulation software Solidworks Flow Simulation flow analysis of symmetrical and asymmetrical profile blades at different airflow velocities was performed. The analysis was carried out by changing the blade's position in respect of the airflow in order to determine the optimum angles of attack. The results were analyzed to identify torques and angles of attack affecting the blades, which allowed deriving the maximum torque values. During designing process the graphs of operating torque were obtained according to an evaluation of blades' rotation frequency. Angle of attack values power generated by rotor of analyzed blades were estimated. This analysis indicated that the asymmetrical blade generates a bigger torque and power than the same chord length blade of a symmetrical profile [2, 3].

2. Profiles of blades chose and analyzing model designing

This work will analyze the blades of two profiles of different cross sections. The coefficients of coordinates of blade profiles are selected from the database of Illinois University Research Institute of Aircraft Engineering [4], which presents more than 1550 different profiles listed in the alphabetical order.

The profiles characteristic to wind power stations of vertical axis of Darrieus [5] type: symmetrical and asymmetrical (one flat side) aeroprofiles. It was decided to select the length of profile's chord (that is the distance between the most remote points in profile's cross section) as 200 mm, because this is the predominant length of chord in the power stations of smaller power.

The asymmetrical profile is selected as the blade profile AQUILA R/C created specially for laminar airflow. In order to receive the spacious model, which calculation results in the airflow were more real, the estimated length of the blade in 1000 mm is chosen. The de-

signed Solidworks model is presented in Fig. 1.

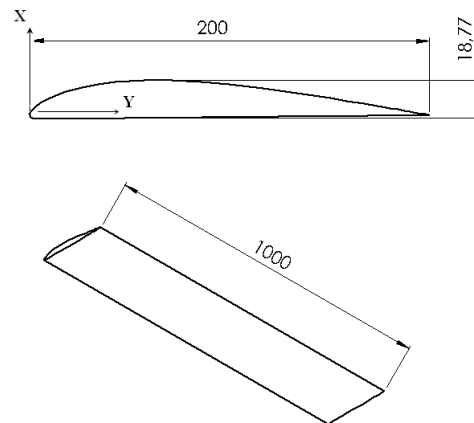

Fig. 1 Cross-section and 3D view of blade profile AQUILA R/C

Material of this blade is chosen carbon fibre – Hexcel AS4C. Area of cross-section 2485.84 mm², surface area excluded ends 405167.34 mm², model volume 2482538.53 mm³, weight 4,418 kg.

The symmetrical profile of blade is selected as EPPLER E297. The blade of this profile is also modeled at 1000 mm length so that the calculation results could be compared. The designed model in Solidworks environment is presented in Fig. 2.

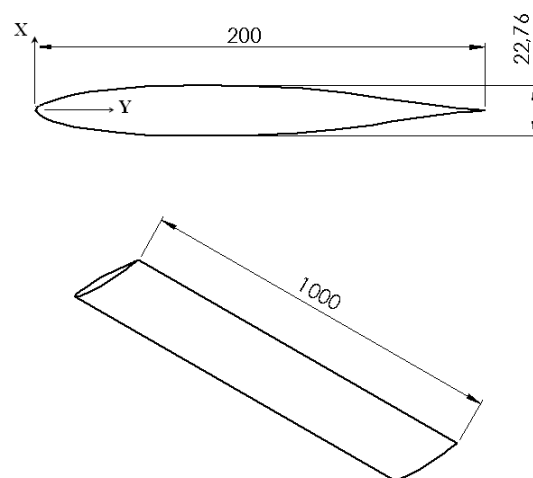

Fig. 2 Cross-section and 3D view of blade profile EPPLER E297

Material of this blade is chosen carbon fibre – Hexcel AS4C. Area of cross-section 3055.43 mm², surface area excluded ends 404041.94 mm², model volume –

3053675.33 mm³, weight – 5,435 kg.

The models of these blades in Solidworks Flow Simulation program are put into the estimated area in the form of rectangular parallelepiped presented in Fig. 3, which dimensions are: 400×400×1000 mm. The length of the estimated area 1000 mm corresponds to the blade's length, thus the modeled airflow does not get through the blade's wings, and the calculation results should correspond the parameters of 1000 mm length blade in the real environment.

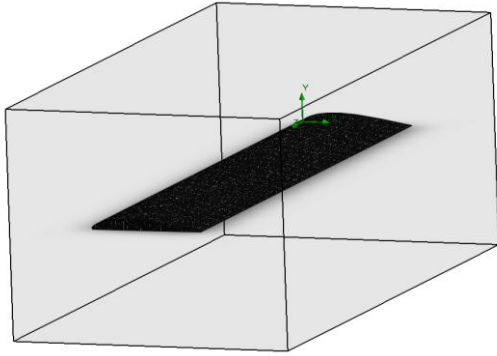

Fig. 3 Calculation area included blade

The Solidworks Flow Simulation program is used in this work to put the blades into 5 airflows of different speeds: 3, 8, 10, 12, 15 m/s. Such speeds of the airflows were selected because they are the most characteristic wind speeds – the speed from 3 to 8 m/s is such, at which the majority of wind power stations start working (rotating), while the speed from 12 to 15 m/s is the working (peak) speed of the wind, at which the wind power stations are working in maximal regime, i.e. the maximal power is acquired. The direction of airflow is considered stable in calculations – only the angle of blade's attack is changed.

In case of each speed of the airflow the blades are rotated around their geometrical axis, which is derived through the geometrical centers of the profiles of blade cross sections, in 5 degrees of the entire circle – 360°. Therefore it is possible to observe the changing forces affecting the blade, torques, pressures, distribution of speeds of airflow as the blade's position is changing with regard to the airflow.

In order to examine universally the aerodynamic characteristics of the blade, the results of the following calculations are expected: static, dynamic and summary flow pressure, projections of airflow's speed to the axes x, y, z, and summary speed of flow, projections of normal forces affecting blade's surface and affecting the entire blade to the axes x, y, z and summary force, projections of frictional forces of airflow affecting the blade's surface to the axes x, y, z, and summary frictional force, and blade's torque around axis z [6, 7].

3. Analysis of CAD results

3.1. Analysis of asymmetrical profile blade

After 360 calculations (rotation in 360° step by 5° in each position by airflows of 5 different speeds), the set values mentioned in chapter 1 are received. The further calculations of blade AQUILA R/C will use the values of

forces affecting the blade, because the values of normal forces affecting the blade's surface are very close to the values of forces affecting the blade, and their percentage expression is presented in (Eq. 1). Besides, the usage of forces affecting the blade in calculations simplifies them as they are concentrated in the blade's axis:

$$n = \left(1 - \frac{F_{Nsum}^{45/12}}{F_{Ssum}^{45/12}} \right) \times 100\% . \quad (1)$$

The force affecting the blade in the direction of z axis on average makes 0.001% of the summary force. Besides, this force does not create a torque around the rotation axis of the rotor; thus this force will not be taken into account in further calculations. Moreover, the frictional forces affecting the blade's surface are smaller than 0.15 N, when the speed of airflow is maximal – 15 m/s, whereas the values of projections of the blade-affecting forces are significantly bigger, thus the frictional forces will not be taken into account in the further calculations, as well.

When all the forces of small values are rejected, it is received that the main torque of the wing around the rotor's rotation axis is created by the projective components in the directions x and y of the force affecting the blade, together with the blade's torque. The illustrative-estimated scheme of the forces and torques is presented in Fig. 4.

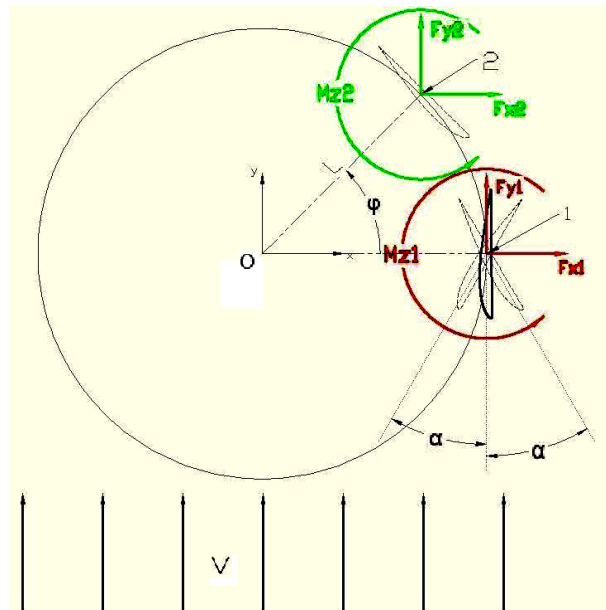

Fig. 4 Diagram of forces and moments operating blade: F_{x1}, F_{x2} – force's projection to the x axis, N; F_{y1}, F_{y2} – force's projection to the y axis, N; M_{z1}, M_{z2} – torque around the blade's axis going through the geometrical centers of sections, Nm; α – variable angle of blade's attack, degrees; L – arm of the torque created by blade around the axis of rotor's center (O point in plane), m; v – speed of airflow, m/s

If the direction of the airflow is considered constant and only the angle of blade's attack α is changed by step 5°, the Solidworks Flow Simulation program helps to receive results, which are systemized and illustrated graphically.

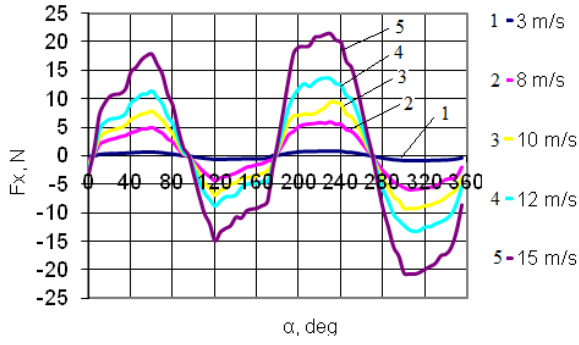

Fig. 5 Force F_x dependence of angle on attack α (asymmetrical profile blade)

According to the diagram (Fig. 5), the values of force F_x acquire both positive and negative values. Besides, the repetition of curves is noticed in case of each different speed of airflow. Therefore the conclusion can be made that the most effective angles of blade's attack during formation of force F_x are stable – regardless the speed of airflow. The maximal achievable force when the speed of airflow is 15 m/s – 21.5 N, when the blade's turn to the airflow is 230°, and the smallest is equal to 20.7 N, when the blade's turn to the airflow is 300°.

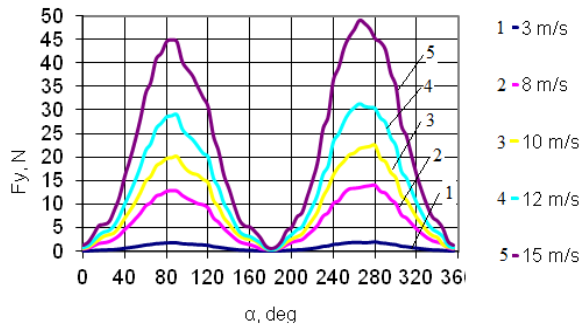

Fig. 6 Force F_y dependence of angle on attack α (asymmetrical profile blade)

According to the diagram (Fig. 6), the values of force F_y are only positive. The same as in the case of force F_x , the repetition of curves is noticed in case of each different speed of airflow, thus the conclusion can be made that the most effective angles of blade's attack during formation of force F_y are stable – regardless the speed of airflow. The maximal achievable force when the speed of airflow is 15 m/s – 49.0 N, when the blade's turn to the airflow is 265°, and the smallest is equal to 0.6 N, when the blade's turn to the airflow is 180°.

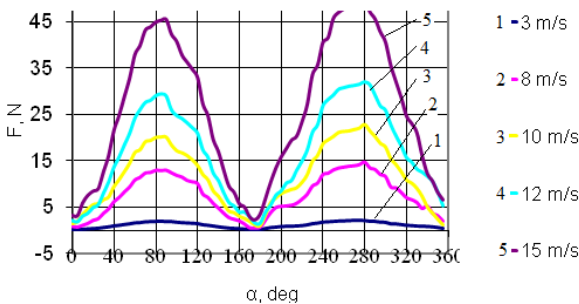

Fig. 7 Force F dependence of angle on attack α (asymmetrical profile blade)

According to the diagram (Fig. 7), the values of force F are only positive. The maximal achievable force when the speed of airflow is 15 m/s – 49.5 N, when the blade's turn to the airflow is 280°, and the smallest is equal to 2.4 N, when the blade's turn to the airflow is 175°.

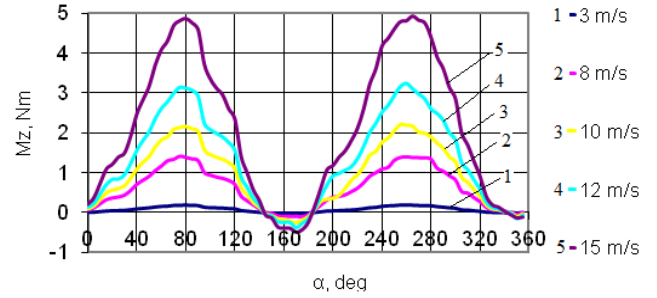

Fig. 8 Moment M_z dependence of angle on attack α (asymmetrical profile blade)

According to the diagram (Fig. 8), the values of torque M_z are significantly positive, and negative ones are relatively small. The same as in the case of forces F_x and F_y , the repetition of curves is noticed in case of each different speed of airflow, thus the conclusion can be made that the most effective angles of blade's attack during formation of torque M_z are stable – regardless the speed of airflow. The maximal achievable torque when the speed of airflow is 15 m/s – 4.9 Nm, when the blade's turn to the airflow is 265°, and the smallest is equal to 0.5 Nm, when the blade's turn to the airflow is 170°.

Following the scheme presented in Fig. 4 and received modeling results of the flows, the analysis is done, what the blade's torque around the rotor's rotation axis is when the blade travels in circle without changing its attack angle with regard to the rotor's rotation axis. The estimated rotation diameter is selected to calculate the torques – 2 m. This means that the rotation radius of 1 m length (torque's arm) will be used for calculations. Following the scheme presented in Fig. 4, the torque equation is written around the point O when the blade's position is in the point 2:

$$M_{O2} = -F_{x2}L\sin\varphi_2 + F_{y2}L\cos\varphi_2 + M_{z2}, \quad (2)$$

where F_{x2} is projection of blade-affecting force to the axis x, N; F_{y2} is projection of blade-affecting force to the axis y, N; M_{z2} is blade-affecting moment, Nm; L is beam of rotation of blade around point O, m; φ_2 is rotation angle of blade, deg.

The calculations are done according to the received modeling results of the flows, thus the φ step is considered to be 5°. The cycle calculations of blade's rotation around point O are done, according to the following system of equations:

$$\begin{cases} M_{O0} = -F_{x0}L\sin 0 + F_{y0}L\cos 0 + M_{z0}; \\ \dots \\ M_{On} = -F_{xn}L\sin\varphi_n + F_{yn}L\cos\varphi_{2n} + M_{zn}; \\ \dots \\ M_{O355} = -F_{x355}L\sin 355 + F_{y355}L\cos 355 + M_{z355}. \end{cases} \quad (3)$$

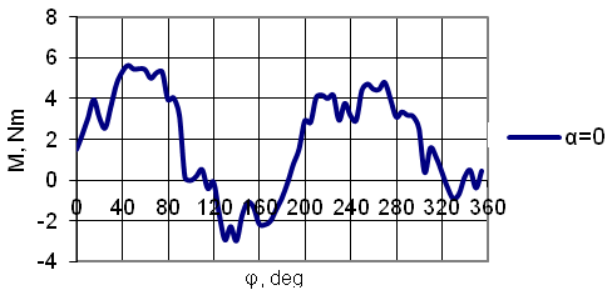

Fig. 9 Moment of blade dependence on blade position according to point O (assymetrical profile blade)

According to the diagram (Fig. 9), the torque is quite unstable and pulsating as the blade’s position with regard to point O changes. Therefore the calculations of blade-affecting torques are done when the angle of blade’s attack α changes from -175° to 180° by step 5° . The calculations are done analogically to the expressions presented in 2 and 3.

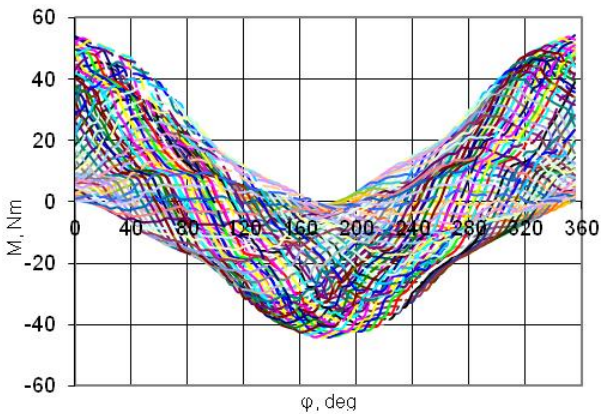

Fig. 10 Moment of blade dependence on blade position according to point O, when angle of attack α is variable (assymetrical profile blade)

According to this sequence of blade-affecting torques (Fig. 10), the maximal and minimal values in each different point of φ depend on the angle of blade attack α . Therefore in order to get the dependence of the angle of blade attack α from the blade’s rotation angle φ it is necessary to examine the sequence of torque curves presented in Fig. 10, by choosing maximal and minimal torques in each rotation angle φ .

Maximal and minimal values shown in Fig. 11.

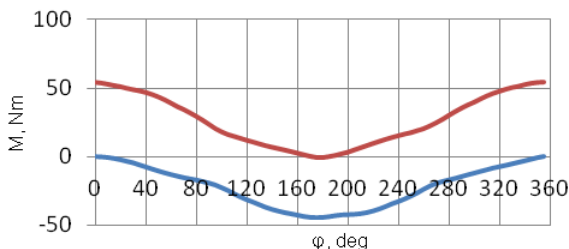

Fig. 11 Maximal and minimal moment of blade dependence on blade position according to point O (assymetrical profile blade)

In order to determine, which working curve is more effective, it is necessary to determine, according to which curve the work performed by the torque is bigger. The value of work is received when the integral of the

torque is calculated:

$$A_{M_{min}} = \int_0^{355} |M_{min}| d\varphi ; \tag{4}$$

$$A_{M_{max}} = \int_0^{355} |M_{max}| d\varphi . \tag{5}$$

According to the received values, the bigger work performed by the torque is received when the curve is affected by the torques illustrated in $M_{maximal}$ torque curve. Following these calculations and dependence of blade-affecting torques on the attack angle α shown in Fig. 10, the dependence of the blade’s attack angle α is received in the blade’s position φ with regard to point O.

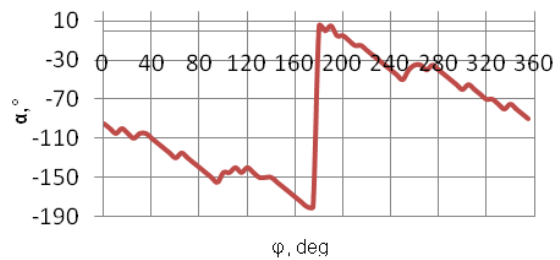

Fig. 12 Angle of attack dependence on blade position according to point O

According to the diagram (Fig. 12), in the critical interval, which segment is from 175° to 180° , the blade’s attack angle has to change by 185° degrees.

3.2. Analysis of symetrical profile blade

Due to EPPLER E297 profile is symmetrical, it is needed to perform only 180 calculations, after it was got 2.1 paragraph refered values. For the further EPPLER E297 blade calculations will be used forces and moments as assymetrical profile blade case.

When all the forces of small values are rejected, it is received that the main torque of the wing around the rotor’s rotation axis is created by the projective components in the directions x and y of the force affecting the blade, together with the blade’s torque. The illustrative-estimated scheme of the forces and torques is presented in Fig. 4.

If the direction of the airflow is considered constant and only the angle of blade’s attack α is changed by step 5° , analogy are got forces and torques dependences of angle on attack:

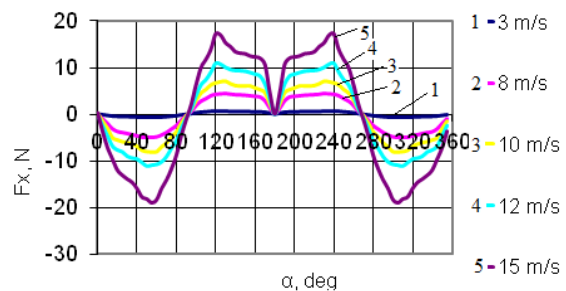

Fig. 13 Force F_x dependence of angle on attack α (symetrical profile blade)

According to the diagram (Fig. 13), the values of force F_x acquire both positive and negative values. Besides, the repetition of curves is noticed in case of each different speed of airflow. Therefore the conclusion can be made that the most effective angles of blade's attack during formation of force F_x are stable – regardless the speed of airflow. The maximal achievable force when the speed of airflow is 15 m/s – 17.3 N, when the blade's turn to the airflow is 120° or 240°, and the smallest is equal to 20 – 18.9 N, when the blade's turn to the airflow is 55° or 305°.

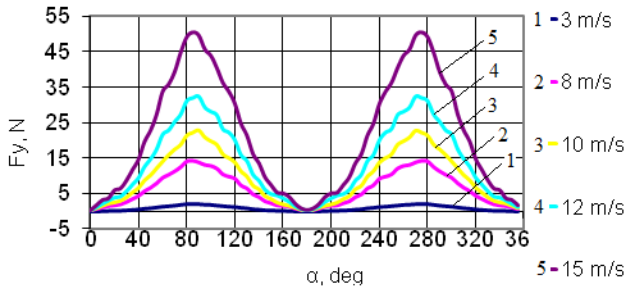

Fig. 14 Force F_y dependence of angle on attack α (symmetrical profile blade)

According to the diagram (Fig. 14), the values of force F_y are only positive. The same as in the case of force F_x , the repetition of curves is noticed in case of each different speed of airflow, thus the conclusion can be made that the most effective angles of blade's attack during formation of force F_y are stable – regardless the speed of airflow. The maximal achievable force when the speed of airflow is 15 m/s – 50.5 N, when the blade's turn to the airflow is 85° and 275°, and the smallest is equal to 0.04 N, when the blade's turn to the airflow is 0° and 180°.

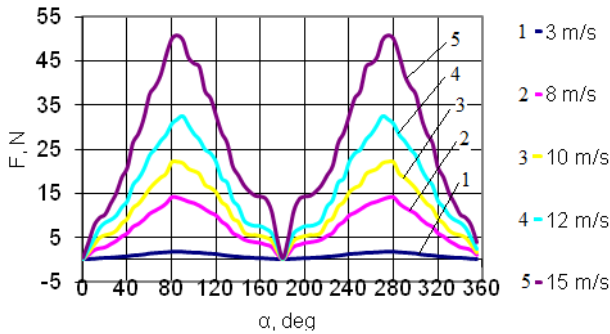

Fig. 15 Force F dependence of angle on attack α (symmetrical profile blade)

According to the diagram (Fig. 15), the values of force F are only positive. The maximal achievable force when the speed of airflow is 15 m/s – 50.5 N, when the blade's turn to the airflow is 85° and 275°, and the smallest is equal to 0.3 N, when the blade's turn to the airflow is 0° and 180°.

According to the diagram (Fig. 16), the values of torque M_z are significantly positive, and negative ones are relatively small. The same as in the case of forces F_x and F_y , the repetition of curves is noticed in case of each different speed of airflow, thus the conclusion can be made that the most effective angles of blade's attack during formation of torque M_z are stable – regardless the speed of

airflow. The maximal achievable torque when the speed of airflow is 15 m/s – 5.1 Nm, when the blade's turn to the airflow is 85° and 275°, and the smallest is equal to -0.08 Nm, when the blade's turn to the airflow is 25° and 335°.

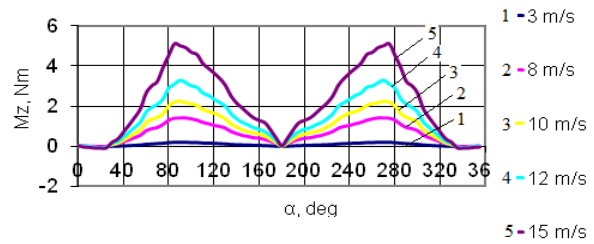

Fig. 16 Moment M_z dependence of angle on attack α (symmetrical profile blade)

Analogy to asymmetrical profile blade case is calculated torque around the point O:

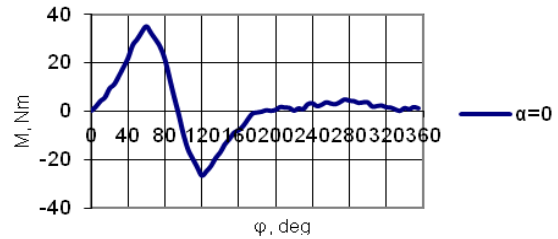

Fig. 17 Moment of blade dependence on blade position according to point O (symmetrical profile blade)

According to the dependence (Fig. 17), the torque is quite unstable and pulsating as the blade's position with regard to point O changes. Therefore the calculations of blade-affecting torques are done when the angle of blade's attack α changes from -175° to 180° by step 5°. The calculations are done analogically to the expressions presented in Eqs. (2) and (3).

Analogy to asymmetrical profile blade case is calculated curves of maximal and minimal torques, travel through calculations is shown in diagrams (Fig. 18, Fig. 19, Fig. 20).

According Eq. (4) and (5) is found more effective curve and ascertained blade's attack angle α depending on blade's position ϕ with regard to point O.

In this case there is different regularity than

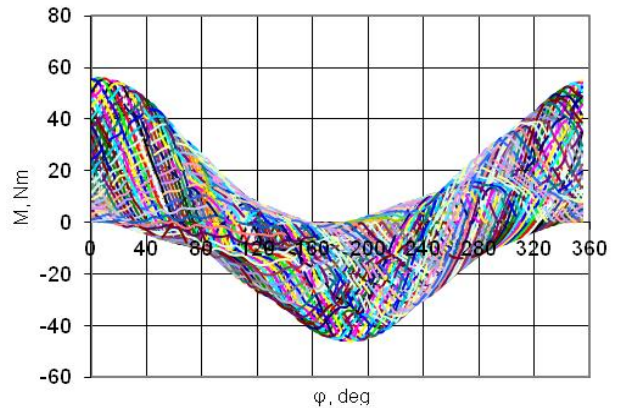

Fig. 18 Moment of blade dependence on blade position according to point O, when angle of attack α is variable (symmetrical profile blade)

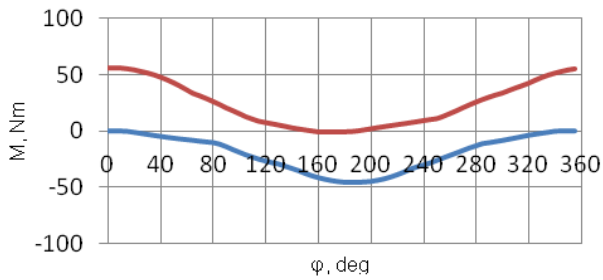

Fig. 19 Maximal and minimal moment on blade dependence of blade position according to point O (symmetrical profile blade)

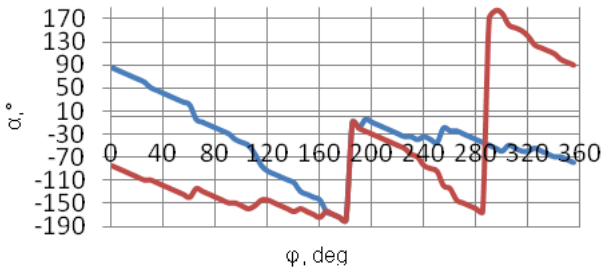

Fig. 20 Angle of attack dependence on blade position according to point O (symmetrical profile blade)

asymmetrical blade. Maximal torques according point O are achieved when there are two different angles of blade attack. Therefore there is eliminating curve which means higher fluctuation of angle of attack. After eliminating it is got new curve.

According to the dependence (Fig. 21), in the critical interval, which segment is from 185° to 190° , the blade's attack angle has to change by 170° degrees.

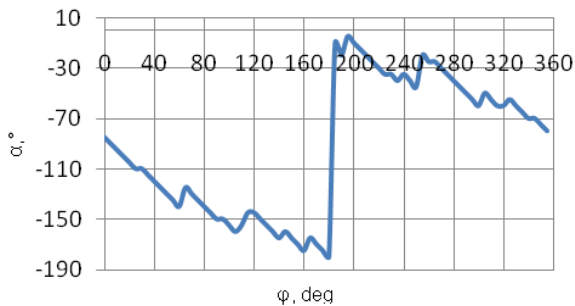

Fig. 21 Angle of attack dependence on blade position according to point O (symmetrical profile blade)

4. Moments calculation of rotors made from few blades

Until now it has been analyzed, what torques appear when one blade is in the airflow. Below the summary torques are calculated when the wind-wheel (rotor) consists of two or three blades. The bigger number of blades is not taken into account because the modeling peculiarities of airflow may result in additional errors, which appear when the overlap of blades is not taken into account, due to increased turbulences of flows, etc.

First of all, the diagrams of torques of the blade of asymmetrical profile AQUILA R/C profile are received for comparison with one blade and when two (180° with regard to each other) and three (120° with regard to each other) blades are combined. The summary torques are encountered when the torques of each point are summed up

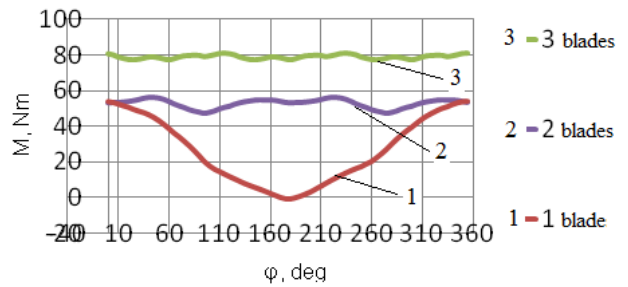

Fig. 22 Moments of rotor composed from different amount of blades

by moving them by certain number of degrees.

According to the Fig. 22, in presence of different number of blades, not only the torque generated by the rotor but also the pulsation of torques differ. The pulsation of torques is calculated in percentage expression of relation of difference between the maximal and minimal torques with maximal torque:

$$p_1 = \left| \frac{M_{1max} - M_{1min}}{M_{1max}} \right| \times 100\%; \quad (6)$$

$$p_2 = \left| \frac{M_{2max} - M_{2min}}{M_{2max}} \right| \times 100\%; \quad (7)$$

$$p_3 = \left| \frac{M_{3max} - M_{3min}}{M_{3max}} \right| \times 100\%. \quad (8)$$

The pulsation of torque of rotor with three blades is significantly smaller even when it is compared to the pulsation of torque of rotor with two blades.

Besides, the nominal powers of rotors with different numbers of blades are calculated using the expression provided below:

$$P = \frac{A}{t}, \quad (9)$$

where: t is time of one period, s; A is job of rotary moment, J; calculated integrating rotary moment:

$$A = \int_0^{355} |M| d\varphi, \quad (10)$$

where: M is rotary moment of rotor, Nm; φ is turn of blade, rad.

When the obtained values are used, the nominal power generated by the rotor of asymmetrical profile (when the rotor does not rotate and the wind's speed is 15 m/s) is received:

$$P_1 = 138.25 \text{ W, when the rotor consists of 1 blade;}$$

$$P_2 = 276.50 \text{ W, when the rotor consists of 2 blades;}$$

$$P_3 = 414.75 \text{ W, when the rotor consists of 3 blades.}$$

The analogous calculations of torques with different numbers of blades are done for the rotor with blades of the symmetrical profile EPPLER E297 with one blade and when two (180° with regard to each other) and three (120° with regard to each other) blades are combined. The summary torques are encountered when the torques of each point are summed up by moving them by certain number of degrees.

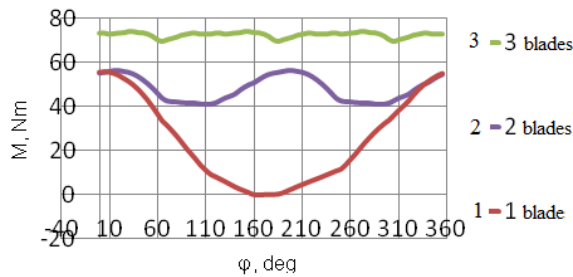

Fig. 23 Moments of rotor composed from different amount of blades

The torque pulsations are calculated analogically:

$$p_1 = \left| \frac{M_{1max} - M_{1min}}{M_{1max}} \right| \times 100\%; \quad (11)$$

$$p_2 = \left| \frac{M_{2max} - M_{2min}}{M_{2max}} \right| \times 100\%; \quad (12)$$

$$p_3 = \left| \frac{M_{3max} - M_{3min}}{M_{3max}} \right| \times 100\%. \quad (13)$$

Analogically to the blade of asymmetrical profile, it is seen that the pulsation of torque of rotor with three blades is significantly smaller even when it is compared to the pulsation of torque of rotor with two blades

When the obtained values are used, the nominal power generated by the rotor of asymmetrical profile (when the rotor does not rotate and the wind's speed is 15 m/s) is received:

$P_1 = 126,24 \text{ W}$, when the rotor consists of 1 blade;

$P_2 = 252,48 \text{ W}$, when the rotor consists of 2 blade;

$P_3 = 378,72 \text{ W}$, when the rotor consists of 3 blade.

Besides, it is noticed that the torque and generated nominal power of the rotor with the blades of symmetrical profile are smaller, and the pulsation of torque is bigger. And these are negative factors with regard to effectiveness and durability of construction, i.e. bigger pulsation causes bigger vibrations of the rotor.

5. Conclusions

1. The testing results of flows of blades of two different profiles helped to determine the following:

- the blade-affecting forces and torques depend on their position with regard to the rotation axis;

- the blade-affecting torques depend on the attack angles of blades. The optimal blade attack angles were encountered, in presence of which the biggest torques are generated. The dependences of attack angles on the position of blades around the rotation axis were formed. The critical change angles of blade attack were determined;

- the work curves of torques generated by blades were modeled taking into account the speed of resistance airflow, which appears when the blade moves in orbicular trajectory.

2. There were determined the values of torques generated from the analyzed blades, which form the rotors. The pulsation of maximal torque was calculated in presence of different numbers of blades. It was determined that when rotor consists of three blades, the pulsation is the

smallest and its values are equal to 4.41%, when the blade's profile is asymmetrical, and to 6.05%, when the blade's profile is symmetrical. As the power created by the torque generated by the blade of symmetrical profile is smaller and pulsation is bigger if compared to the asymmetrical profile, it is considered that the blades of asymmetrical profile are more suitable for the wind power stations of Darrieus type.

References

1. **Gulbinas, A.** 2007. Wind Power Plant power regulation. [accessed 15 May 2012] Available from Internet: http://vddb.laba.lt/fedora/get/LT-eLABa-0001:J.04~2007-ISSN_1392-1134.V_39.N_3.PG_81-94/DS.002.0.01.ARTIC.
2. **Paulauskas, A; Tamonis M.** 2005. Region power plant development perspective. [accessed 22 May 2012]. Available from Internet: http://www.ebiblioteka.lt/resursai/Konferencijos/VLV_K_051028/3%20sekcija/III10_Paulauskas.pdf.
3. **Lithuanian Wind Energy Association.** Wind resources. [accessed 15 Feb. 2012]. Available from Internet: http://www.lwea.lt/portal/index.php?option=com_content&view=article&id=59&Itemid=76&lang=lt.
4. **UIUC Airfoil Coordinates Database** [accessed 04 May 2012]. Available from Internet: http://www.ae.illinois.edu/m-selig/ads/coord_database.html.
5. **Sheldahl, Robert E.** 1981. Comparison of Fields and Wind Tunnel Darrieus Wind turbine Data. [accessed 9 May 2012]. Available from Internet: <http://www.estonia.ca/koit/Kool/L%F5put%F6%F6/Mud%20materjalid/Sandia/Teisej%E4rgulised/Sandia%20802469.pdf>.
6. **Gasch, R.; Twele, J.** 2002. Wind Power Plants: Fundamentals, Design, Construction and Operation, Berlin: Solarpraxis AG.
7. **Barauskas, R.** 1998. The Finite Element Method Basics, Kaunas: Technologija, 375 p. (in Lithuanian).

M. Galdikas, A. Vilkauskas

VĖJO JĖGAINĖS MENČIŲ AERODINAMINIŲ CHARAKTERISTIKŲ TYRIMAS

R e z i u m ė

Straipsnyje pateiktas modeliavimo programa Solidworks Flow Simulation atlikta asimetrinio ir simetrinio profilių menčių srautų analizė esant skirtingiems oro srauto greičiams. Analizė atlikta keičiant mentės padėtį oro srauto atžvilgiu, kad būtų galima nustatyti optimalius atakos kampus. Pagal gautus rezultatus rasti mentės veikiantys sukimo momentai ir menčių atakos kampai, kurių dėka gaunamos maksimalios sukimo momentų reikšmės.

Atlikus modeliavimą, įvertinant menčių sukimosi dažnį, gautos darbinės sukimo momentų kreivės. Darbe apskaičiuojama vėjaračio sudaryto iš skaičiuojamųjų menčių generuojama galia ir stabdymo režimo atakos kampų reikšmės. Atlikus analizę nustatyta, kad tos pačios stygos ilgio asimetrinio profilio mentė generuoja didesnę sukimo

momentą, tuo pačių ir galią, negu simetrinio profilio mentė.

M. Galdikas, A. Vilkauskas

RESEARCH OF AERODYNAMICS
CHARACTERISTICS OF WIND POWER PLANT
BLADES

S u m m a r y

The article presents using flow designing fluid simulation software SolidWorks Flow Simulation flow analysis of symmetrical and asymmetrical profile blades at different airflow velocities was performed. The analysis was carried out by changing the blade's position in respect of the airflow in order to determine the optimum angles of

attack. The results were analyzed to identify torques and angles of attack affecting the blades, which allowed deriving the maximum torque values.

During designing process the graphs of operating torque were obtained according to an evaluation of blades' rotation frequency. Angle of attack values under braking conditions and power generated by rotor of analyzed blades were estimated. This analysis indicated that the asymmetrical blade generates a bigger torque and power than the same chord length blade of a symmetrical profile.

Keywords: wind power plant, blade, flow, angle of attack (pitching).

Received September 03, 2012

Accepted June 17, 2013