

## Bonded end anchor for stator tensioning rods

S. Kuosmanen\*, H. Eskelinen\*\*, J. Varis\*\*\*

\*Lappeenranta University of Technology, Skinnarilankatu 34, 53850 Lappeenranta, Finland,

E-mail: sami.kuosmanen@lut.fi

\*\*Lappeenranta University of Technology, Skinnarilankatu 34, 53850 Lappeenranta, Finland,

E-mail: harri.eskelinen@lut.fi

\*\*\*Lappeenranta University of Technology, Skinnarilankatu 34, 53850 Lappeenranta, Finland, E-mail: juha.varis@lut.fi

**crossref** <http://dx.doi.org/10.5755/j01.mech.19.5.5534>

### 1. Introduction

The increasing demand for renewable energy has resulted in a need for more efficient energy conversion methods. For wind energy, improving direct-drive, permanent magnet excited generators is one focus. These generators (just like electric motors) have a stator structure made from coated sheets of specially developed electrical steel that are stacked and then bound to hold them tightly together. At each end of the stack is a thick structural steel plate that distributes the binding loads evenly across the stacked sheets. New approaches for joint and geometry solutions for different mechanical structures have been developed at Lappeenranta University of Technology, such as Lohtander et al. [1] have studied.

The sheets need to be bound to establish the required electrical properties and enhance sheet-to-sheet heat conduction for cooling. Binding also inhibits sheet-to-sheet movement, reducing abrasive wear of the lamination coatings. Common lamination binding methods make use of a hydraulic press to force the laminations together. In one approach, an external load bearing structure is fixed to the stack to maintain compression when hydraulic pressure is removed. In another approach, compression is maintained by running weld beads from sheet-to-sheet along the outer and inner diameters of the stack. The primary shortcoming of these methods is that vibration and thermal cycling over the life of the generator results in abrasion and wear of the sheet coatings causing the lamination stack to loosen, which degrades both electrical properties and cooling [2]. Fig. 1 shows a loose stator lamination stack.



Fig. 1 A loose stator stack [3]

To combat stack loosening, a method is needed for maintaining the initial design compressive forces that will compensate for changing stack length over the design life of the generator. Designing elasticity into the structural

restraint system is one way to accomplish this.

A simple elastic structure can be developed using tension rods that pass through the lamination stack (Fig. 2). Tension rods apply compressive force based on Hooke's Law, where force is the product of the spring constant and the amount of rod pre-stretch. For a solid rod, the spring constant is the modulus of elasticity of the rod material. Ideally, the force applied by each tension rod should be insensitive to small changes in length over time so the elastic modulus should be relatively small and rod pre-stretch should be relatively large.

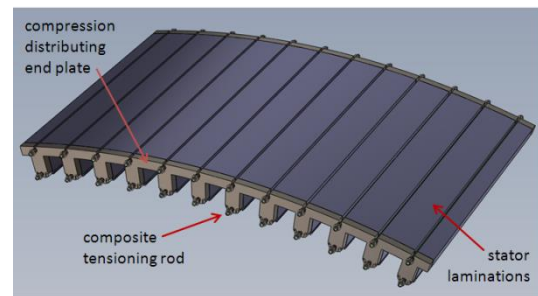

Fig. 2 Concept showing stator laminations bound using composite tensioning rods

For best electromagnetic performance, tension rods passing through the laminations of an electromagnetic machine also must be non-conductive and non-magnetic. Certain glass fiber composite rods offer the needed combination of properties. They have relatively low elastic modulus, can accommodate significant stretch while remaining elastic, and are both non-conductive and non-magnetic. Here, we investigate an approach for fabricating a glass fiber composite tension rod.

#### 1.1. Research problem

To support tension in a rod passing through the lamination stack, it must be anchored at each end. One way of enabling this is to fix larger diameter anchoring sleeves to each end of the rod capable of withstanding the required high tension forces (Fig. 3).

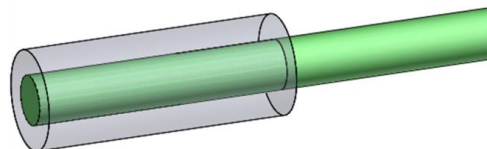

Fig. 3 Rod end with larger diameter sleeve

In this study, adhesive bonding was investigated as the sleeve fixing method. The goal was to identify a suitable adhesive and establish the most appropriate bond layer geometry (thickness and area).

The research problem can be stated as follows. Is it possible to bond the larger diameter sleeve to the rod? What are the suitable adhesives and dimensions in the bonded joint?

Pull tests were carried out by fabricating tension rods with a bonded sleeve at one end. Sleeve material was not a focus of the research, but a few different sleeve materials were tested. Different adhesives, adhesive layer thicknesses, and sleeve lengths were tested. Each rod was tested in a pull testing machine to determine the magnitude of force leading to failure; either in the rod itself, the end sleeve, or the adhesive bond. The pull tests were not intended to be rigorous. Rather, the intent was to evaluate a few selected adhesives to determine if it would be possible to produce composite tension rods using an adhesive bond. The evaluation process flow is shown in Fig. 4.

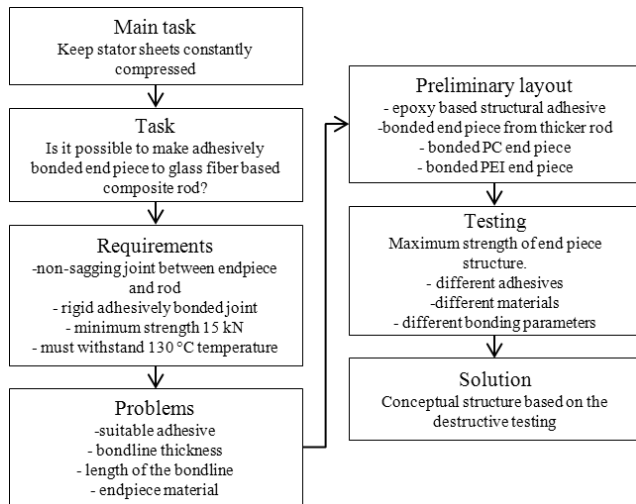

Fig. 4 The process flow for evaluating the anchoring structure of a composite tension rod

In this research, the effect of environmental temperature on the bonded joint was not tested. However, only adhesives designed to function continuously at the highest expected temperature, approximately 130°C, were evaluated. Because stator laminations do not experience significant dynamic loading during normal operation, only static load was investigated. The minimum load carrying capacity for each bonded joint should be at least 15 kN. Only shear stress is present at the joint. The sleeve-to-rod connection must be rigid, not elastic.

## 2. Research methods

The tensioning rods were polyester resin reinforced axially-oriented fiberglass with a nominal diameter of 0.375 inches (9.5 mm). This rod material is commercially available. These tests used Grade HIR Glasrod by Röchling Glastic Composites. Three different materials were used to produce the larger diameter anchoring sleeves. These were Grade HIR Glasrod, polycarbonate (PC) rod, and a 30% glass-filled polyetherimide (PEI) rod. The outer diameters were 0.75 in (19 mm) for the Glasrod, 40 mm (1.57 in) for the PC, and 40 mm for the PEI. Each sleeve

was cut to length and then bored to slip over the rod. The precise inner diameter of the sleeve bore was varied to vary adhesive bond layer thickness. The sleeves, adhesives used, and the relevant dimensions are shown in Table 1.

Table 1  
Sleeve materials and dimensions, adhesives, and bond line thicknesses

Sleeve	Diameter (mm)	Length (mm)	Bond Line Thickness (mm)	Adhesive
Glasrod	9.5	40	0.20	Loctite 9514
Glasrod	9.5	40	0.20	3M DP410
polycarbonate	40	60	0.20	3M DP460
polycarbonate	40	60	0.20	Loctite 9514
Glasrod	9.5	40	0.10	Loctite 9514
PEI+30% glass fiber	40	60	0.15	Loctite 9514

Loctite and 3M adhesives were evaluated. The type and specific formulations were selected based on recommendations from 3M and Loctite representatives and the available product data, taking into account the temperature requirement and the need for joint rigidity. Only epoxy adhesives satisfied the rigidity requirement.

The appropriate range for adhesive layer thickness was set according to manufacturer recommendations and information available from research literature. According to the literature, the most suitable bond layer thickness should be between 0.05 and 0.2 mm [4]. Bond length was chosen to provide sufficient bond area without exceeding generator stator space constraints.

Prior to bonding, the bond surfaces were degreased. The rod end was lightly sanded to optimize adhesion. The inner sleeve surface was already rough as a result of the boring operation. Next, the adhesive was applied to the rod surface and to the inside surface of the sleeve bore. Finally, the joint was assembled. The theoretical bond surface area is illustrated in Fig. 5.

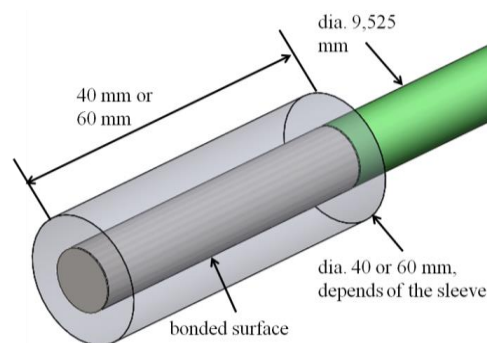

Fig. 5 The bonded cylindrical surface at the end of rod

Curing of each adhesive bond was carried out according to manufacturer specifications. The 3M epoxies were 2-component. They were cured for a minimum of 12 hours at room temperature. The Loctite 9514 is a heat

curing adhesive. To achieve maximum shear strength, it was cured by placing the entire rod assembly into a curing oven for the specified duration and at the specified temperature. Once cured, the Loctite 9514 assemblies were allowed to cool down with the oven.

Pull testing was carried out by inserting each assembled tensioning rod sample into the pull test machine. Laser cut steel plate tooling held the anchor end of the sample in the upper fixed part of the pull tester (Fig. 6). The smaller rod end of the sample was clamped between fixing jaws in the bottom moving part of the machine. The plate tooling was designed to apply force to the anchor sleeve evenly over its bottom surface. This setup results in nearly pure shear stress across the adhesive bond and simulates the way the tensioning rod would be used in a generator to compress stator laminations. Each test sample was pulled until failure, and the maximum force achieved was recorded. Strain was not recorded.

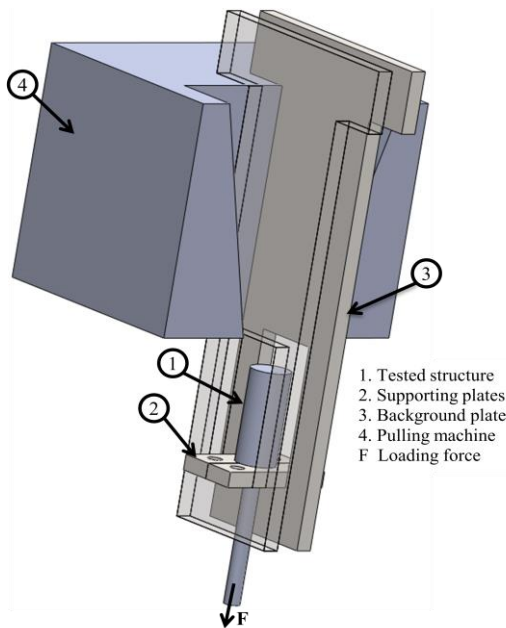

Fig. 6 Pull tester tooling holds the rod anchor sleeve. Lower rod clamping jaws are not shown

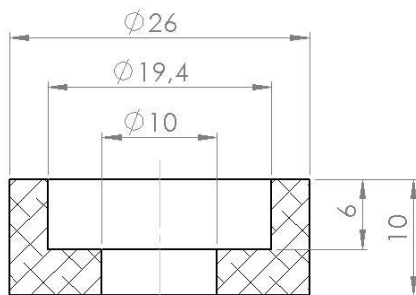

Fig. 7 Stress distributing support washer

After pull testing the initial set of tensioning rod samples, two things became evident. First, the best performing adhesive was clearly the Loctite 9514. Second, adding a supporting washer to better distribute pulling force over the end surface of the tensioning rod anchor should improve performance. Aluminum support washers were designed (Fig. 7) and fabricated. Using only the Loctite 9514 adhesive, more tensioning rod samples were fabricated and assembled with the new supporting washers

bonded to the rod and the face of the anchoring sleeve (Fig. 8). The basic parameters for the new tensioning rods are listed in Table 2.



Fig. 8 Test specimen with silicone sealant and the washer after the pulling test

Table 2

Tests with support washer

Sleeve	Length, mm	Bond line thickness, mm	Adhesive
Glasrod + washer	60	0.15	Loctite 9514
PEI+30% fiberglass + washer	60	0.15	Loctite 9514

To better understand the effect of Glasrod tensile strength on the tensioning rod samples, 2 plain rod samples were also pull tested to determine the maximum force each would support before failure. For these pull tests, the rods were clamped from both ends with the standard clamping jaws of the tension tester.

### 3. Results

For the pull tests, the main interest was in the maximum strength of the anchor structure. Uniaxial tension force with respect to time was recorded for each sample tested. Time was recorded to establish any correlation between maximum tensile force at failure and the stretching speed. Each test concluded with the breaking of the sample. Fig. 9 illustrates a typical result. Primary test results are given by Table 3 for the tensioning rod samples and Table 4 for the two plain Glasrods.

Table 3

Test results

Sleeve	Length (mm)	Bond Line Thickness (mm)	Adhesive	Joint Strength (kN)
Glasrod	40	0.2	Loctite 9514	30.8
Glasrod	40	0.2	Loctite 9514	29.2
Glasrod	40	0.2	3M DP410	16.8
Glasrod	40	0.2	3M DP410	12.2
polycarbonate	60	0.2	3M DP460	11.3
polycarbonate	60	0.2	Loctite 9514	4.6
polycarbonate	60	0.2	Loctite 9514	6.7
Glasrod	40	0.1	Loctite 9514	25.7
PEI+30% fiberglass	60	0.15	Loctite 9514	0.7
Glasrod + washer	60	0.15	Loctite 9514	28.1
Glasrod + washer	60	0.15	Loctite 9514	30.4
PEI+30% fiberglass + washer	60	0.15	Loctite 9514	6.4

Table 4  
Glasrod maximum uniaxial tension force

Plain glasrod	Force before breaking, kN
Rod 1.	36.4
Rod 2.	38.6

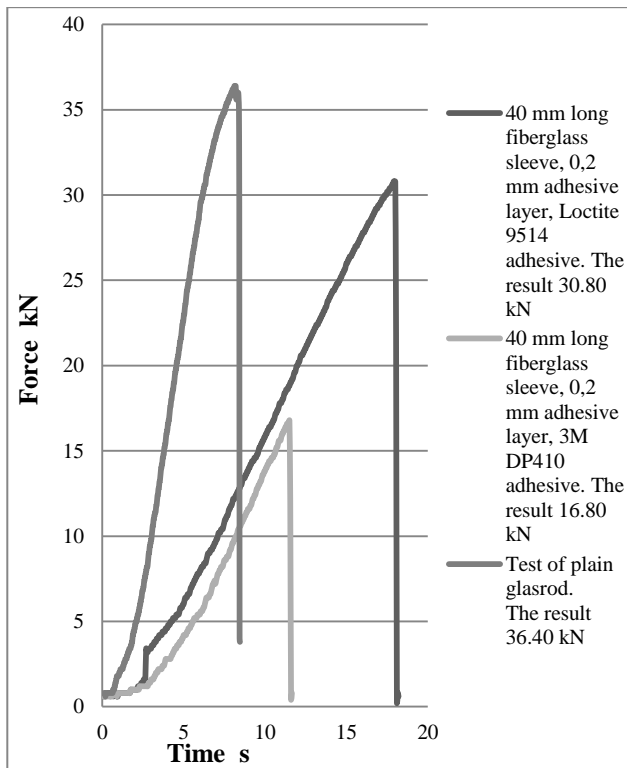

Fig. 9 Typical pull test result

#### 4. Analysis

The tensioning rod samples fabricated with Glasrod sleeves and Loctite 9514 withstood almost twice the required 15 kN load. For Glasrod sleeves bonded with the 3M DP410 adhesive, failures occurred below 15 kN. It might be possible to improve the performance of the 3M adhesive with further investigation and testing. The tensioning rod samples fabricated with the polycarbonate or polyetherimide anchoring sleeves did not perform well. Although the adhesives are recommended for these materials, the pull tests revealed weak bonds between the adhesives and the anchor materials.



Fig. 10 Tensioning rod sample after failure showing a white line (crack) on the sleeve surface

All the tensioning rod samples fabricated with Glasrod anchoring sleeves failed with significant longitudinal cracking of the sleeve (Fig. 10). Since the Glasrod sleeve material is only reinforced with uniaxially oriented fiberglass strands, the material is relatively weak with

respect to radial or circumferential forces. This weakness led to the eventual failure of the tensioning rod assembly. Apparently, increasing forces within the sleeve structure resulted in the longitudinal cracking, which allowed the sleeves to pull away from the tension rod material, adding tension stresses to the shear stress field within the adhesive layer and precipitating failure.

The failure mode for the tensioning rod samples made with polycarbonate and PEI sleeves was different. There was no visible damage to the sleeves. In each case, the sleeve adhesive bond failed, supported force dropped significantly, and the intact sleeve began moving axially along the tension rod material.

Variations in sleeve length did not seem to affect joint strength. The best performing bond line thickness was found to be in the range of 0.15 to 0.20 mm. At 0.10 mm thickness, there was a significant drop in performance, probably because during fabrication, it was very difficult to get the adhesive spread evenly throughout the bond region. Visual inspection of the failed 0.10 mm samples showed areas without adhesive.

Pull testing of the plain rods showed them to be sufficiently strong. They broke at the edge of the pull tester's clamping jaws. Jaw compression resulted in stress discontinuities that precipitated failure. To determine the actual maximum tensile strength of the rods (theoretically 45 kN), an improved holding method would be needed.

The average shear stress in the cylindrical bonded joint can be estimated with the following equation:

$$\tau = \frac{F}{\pi dh}, \quad (1)$$

where  $\tau$  is shear stress,  $F$  is the force in the joint,  $d$  is the average diameter of the bonded joint and  $h$  is the height of the bonded joint.

For a 15 kN load in a 9.52 mm rod with a 40 mm long sleeve, the average shear stress is 12.54 MPa. This is lower than the maximum shear strength of the tested adhesives. Fig. 11 shows how the end piece is stressed in the test.

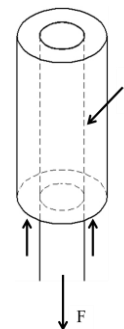

Fig. 11 Loads and forces between the rod and the anchor

#### 5. Conclusions

Based on these tests, it is possible to fabricate a suitable tensioning rod system using a Glasrod rod and an anchoring sleeve made from the same Glasrod material. The bond layer should be in the 0.15-0.20 mm range, and the sleeve length should be at least 40 mm. Loctite 9514 is a suitable adhesive for this application with these dimen-

sions. The tested 3M adhesives were not suitable for this purpose, especially if the reduction of the strength in elevated temperatures is taken in to the account. The Loctite also loses strength at higher temperatures, but based on the manufacturer's published data should retain sufficient strength.

The adhesive bonding of the dissimilar sleeve materials (polycarbonate and PEI) was poor. The materials might work with a more suitable adhesive, however, there could still be an issue with differences in thermal expansion between the rod and sleeve.

### 5.1. Reliability

When fabricating the tensioning rod samples, no special measures were taken to ensure concentricity between the sleeve and rod, therefore the adhesive bond layer may have varied slightly in thickness from one side to the other. Post failure visual inspection performed on some of the samples did not reveal any significant variations. Boring the Glasrod sleeves resulted in microcracking of the inner surface. This microcracking may have influenced failure.

### 5.2. Usability

The usable compression forces that can be applied with tensioning rods can be varied by changing rod diameter and length. A larger diameter results in larger forces, and a longer length results in lower forces. The distribution of compressive forces in a stator structure can be adjusted by changing the position and number of rods.

## 6. Further development

The uniaxial orientation of fiberglass strands in the Glasrod sleeves was clearly a weakness that resulted in longitudinal cracking and failure. A similar fiberglass material with non-oriented fiber strands should perform better. Best results should be obtained with circumferentially oriented fiberglass strands. A more comprehensive evaluation of available adhesives should be carried out to identify alternatives or perhaps better performers. Other methods of fixing the anchoring sleeves to the tensioning rods, such as metallic shrink or crimp fitting should be investigated and tested. Finally, the possibility of fabricating rods with integrated anchors should be investigated.

Long-term strain testing of the Glasrod material and the anchor bonding method will be needed to determine the viability of the composite tensioning rod system. Testing should also be carried out at typical operating temperatures to understand the influence of temperature.

## References

1. **Lohtander, M.; Lanz, M.; Varis, J.; Ollikainen, M.** 2007. Breaking down the manufacturing process of sheet metal products into features, *Mechanika* 64(2): 40-48.
2. **Stone, G.; Boulter, E.; Culbert, I.; Dhirani, H.** 2004. *Electrical Insulation for Rotating Machines - Design, Evaluation, Aging, Testing and Repair*, New York: John Wiley & Sons, 392 p.

3. **Swardt, H.** 2003. *Electric motor design enhancements: ensuring high quality and long term reliability*. Vector (3).
4. **Petrie, E.** 2000. *Handbook of Adhesives and Sealants*. New York: McGraw-Hill, 880 p.

S. Kuosmanen, H. Eskelinen, J. Varis

## SUJUNGTAS ANKERINIS INKARAS STATORIAUS ĮTEMPIMO TRAUKLĖMS

### Re z i u m ė

Pasiūlytas statoriaus plieno lakštų sujungimo metodas. Tiriamoji konstrukcija susideda iš kompozicinės dalies, kuri veikia kaip suspausta spyruoklė. Straipsnyje pateikti preliminarūs statoriaus galinės dalies suspaudimo tyrimo, atlikto esant adheziniam sujungimui, rezultatai.

S. Kuosmanen, H. Eskelinen, J. Varis

## BONDED END ANCHOR FOR STATOR TENSIONING RODS

### S u m m a r y

The presented paper investigates a novel method for binding stator steel sheets. The researched structure consists a composite based solution that acts like a compression spring. In this paper is presented a preliminary research for the end piece of the stator compression structure. It was researched, if an adhesively bonded joint could be utilized.

**Keywords:** adhesively bonded, stator, composite, compressing method.

Received June 15, 2012

Accepted September 05, 2013