

# Experimental research of vibratory slipping of the shaft fastened with tightness in the bushing

**B. Bakšys\*, J. Mikolainis\*\***

\*Kaunas University of Technology, Kęstučio 27, 44312 Kaunas, E-mail: bronius.baksys@ktu.lt

\*\*Kaunas University of Technology, Kęstučio 27, 44312 Kaunas, E-mail: jurgis.mikolainis@stud.ktu.lt

**crossref** <http://dx.doi.org/10.5755/j01.mech.17.5.725>

## 1. Introduction

Press connections and other joining techniques based on plastic deformation methods are widely used in the production process of machinery and other equipment, when it is necessary to transfer big axial forces and torques. The strength and reliability of the joint depends on the initial interference value.

The parts that are joined together with small interference transmit moderate torques and axial forces, as they may accidentally move or turn slightly against each other. Such connections are mainly used for joining small thin-walled parts, which cannot be deformed, i.e., fittings, couplings, locking rings, support bearings. Tightly joined connections are rarely disassembled because the dismounting could damage connected details.

The parts that transmit big forces and torques - plain shaft bearings, bushings, gears of gearboxes, electric motor armature bushings are joined with big interference. These connections are commonly performed by heating one of the joining parts. A tight interference fit between mating parts is obtained by shrinking-on, that is, by heating the outer part to expand the diameter for easy assembly and then cooling so that the outer part contracts. The alternative joining method when the inner part is shrinking by chilling has an advantage, because it is possible to avoid the influence of thermal stresses or strains in the material [1].

However, in manufacturing industry the press-fit connection is the most common method for joining the parts, because it is easy performed and it is not necessary to have any special equipment for maintaining temperature changes. The principle of press-fit joining is that the outer part diameter is smaller than inner part diameter. One of the components is acted by axial force and pressed in another detail with interference. The details are moving against each other thus deforming the connecting surfaces until they fully merge. Press-fit connections, if compared with other methods of elimination the mobility of parts can simplify the design, make easier assembly process and aligning of parts.

The strength of press-fit connection is influenced by forces that occur because of elastic and plastic deformations of inner and outer detail. If the interference between details is the same then the strength of joint depends on the material of details, the speed of assembly process.

The interference of press-fit connection is calculated from the nominal dimensions of joining surfaces, not taking into account the micro unevenness of surfaces, because the uneven surfaces are ripped off and smoothed while pressing. The interference also depends on the area of the connecting surfaces, the error of shape and position-

ing of details.

In the surfaces of press-fit connected details the forces of friction are acting that oppose the relative displacement of details. Recent research show that the excitation of one or both of the mating details with the ultrasound vibration is reducing the friction between interacting surfaces. The samples of different materials - aluminum, copper, brass, stainless steel were tested, and it was concluded that the use of vibrations reduces the friction between the surfaces by up to 80% [2].

The value of friction coefficient depends on the frequency and amplitude of the excitation vibrations. Experimentally changing the parameters of vibration, the relationship between the coefficient of friction and the vibration frequency and amplitude was found [3]. Choosing the appropriate oscillation parameters allows to create the optimal operating conditions and the reduction of friction allows to join the details with lower compression force. Parts can be acted with longitudinal and transverse vibrations; however after implementing piezoelectric elements in the structure it is possible to obtain complex trajectories of vibrations.

Vibrations can be easily generated by industrial vibrators, which are widely produced in machinery market, so the vibration excitation can be implemented in the automated and robotized assembly process. The automatic connection process of cylindrical parts under vibration excitation has been studied in detail, when the parts were connected with clearance. The process of mobile based peg insertion into immobile based bush, while the peg was kinematically excited in axial direction, was analyzed. The experiment showed that the vibration of parts helps to prevent the jamming of parts under one or two contact point conditions, if the appropriate settings and oscillation modes are selected. In addition, it is noted that the connection time is decreasing and friction between parts is reducing if the oscillation frequency is increasing [4].

Modern technologies helps to detect even the smallest vibrations, measure the acceleration of connecting parts, the duration of connection and transmit the received data from the sensors directly to the computers using wireless transmission devices [5]. In automated assembly process, a short connection time of details is very important factor, because under faster assembly process more details can be processed.

On the surfaces of press-fit joints the big contact forces are acting, therefore the parts may result in cracks, if pressed with too great force. Using finite element analysis the deformation of shaft and bushing can be observed and the locations of cracks may be predicted [6].

The vibrations can be implemented not only in the assembly process, but also in other technological proc-

esses. In some cases, the use of excitation may intensify the technological process, which can also be carried out without vibrations. For example, if the cutting tool is under ultrasonic vibrations, the cutting force decreases, work piece has lower thermal influence and the roughness of surfaces decreases [7]. In other cases the technological process may be realized only with the use of vibrations. The principle of vibro-motors, precise positioning devices is based on vibratory slipping or rotating motion of parts, which is caused by high frequency excitation.

The connection process, when the details are connected with interference and excited with vibrations is relatively little explored. The aim of this experiment is to examine the influence of oscillation parameters to the process of slipping the press-fit shaft, its duration, determine the tendencies of vibratory slipping motion and its dynamic characteristics.

## 2. Experimental setup and the technique of vibratory slipping experiment

The experimental setup was mounted for research of vibratory slipping of a shaft fastened in the bushing with interference, as in Fig. 1.

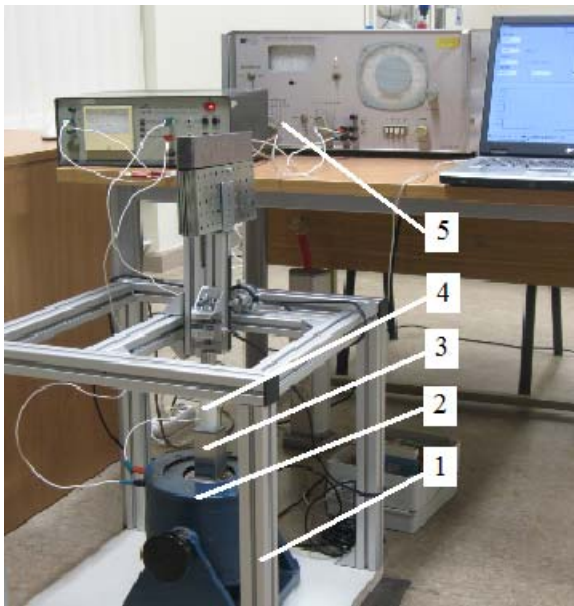

Fig. 1 Vibratory slipping experimental setup: 1 - frame; 2 - electromagnetic vibrator; 3 - bushing; 4 - shaft; 5 - signal generator

The electromagnetic vibrator 2 is fastened to the frame of experimental setup 1. The bushing 3 is attached rigidly to the upper platform of the vibrator 2. The low frequency signal generator 5 generates the vibrations of designated frequency and amplitude for the vibrator platform. The shaft 4 is acted by axial force and slides down into the bushing 3.

The pressing force of a shaft may be gradually changed by increasing the load 1 (Fig. 2). The pressing force is measured by the force sensor 4. The toothed belt 3 together with the shaft move down and rotate the axle of shaft position sensor 2. One spin of the axis generates 3500 pulses, so it is possible to capture even the smallest position changes of the shaft. One pulse of the sensor corresponds to 0.002 mm displacement of a shaft.

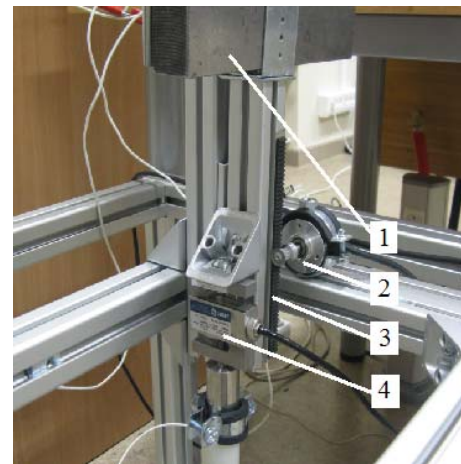

Fig. 2 Sensor arrangement in the experimental setup: 1 - load; 2 - shaft position sensor; 3 - toothed belt; 4 - force sensor

During the high-frequency vibrations contact units of sensor can be seriously damaged because of friction, thus the optical rotational sensor was selected for the measurement of shaft position, which does not contain any contacting details. Before starting the tests, the sensors are calibrated in order to obtain accurate test results.

The structural schema of the experimental setup is shown in Fig. 3.

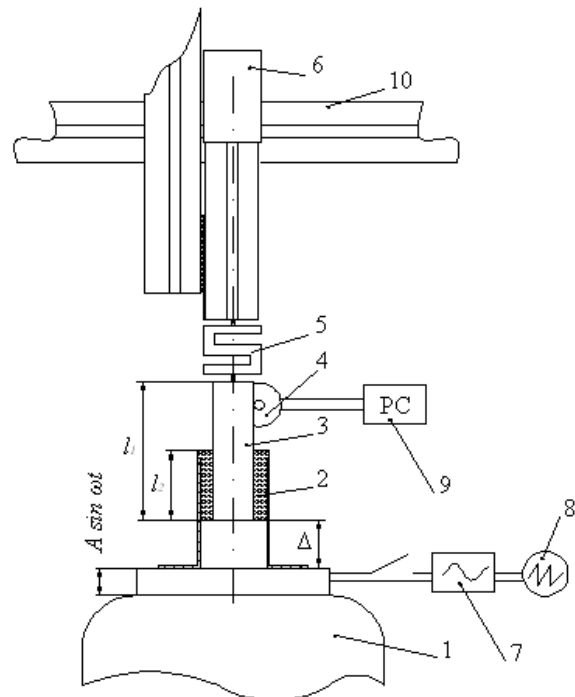

Fig. 3 Structural schema of the experimental setup: 1 - electromagnetic vibrator; 2 - bushing, 3 - shaft, 4 - shaft position sensor, 5 - force sensor, 6 - load, 7 - amplifier, 8 - signal generator, 9 - computer; 10 - frame of setup

The shaft 3 is mounted movably in the direction of connection axis. It is acted by a pressing force of the load 6. The bushing 2 is fixed on the platform of the electromagnetic vibrator 1. Initially the shaft is already inserted into the bushing by the length  $l_2$ , so it only slides by length  $\Delta$  until it touches the platform of vibrator. These conditions eliminate the alignment errors of details. The contacting

area is constant, thus the friction force is also constant. Shaft's diameter is greater than the diameter of the hole in the bushing, thus the normal pressure and frictional forces occur in the surfaces that resist the relative displacement of connected components. The bushing is excited by harmonic vibrations  $Asin\omega t$  in the direction of connection axis. The excitation signal is formed by a low frequency signal generator 8 and is amplified by amplifier 7. The movement of the shaft is registered by the shaft position sensor 4. The data of experiment are processed, compiled and analyzed with computer 9.

### 3. Experimental results

The joining and dismounting of parts require big forces, therefore the parts are made of relatively soft material - plastics, so that they can be easily dismantled after the test. The dimensions of the components used in the experiment and other technical characteristics:

- shaft - length 100 mm, diameter 30.5 mm, material - plastics;
- bushing - length 50 mm, hole diameter 29.95 mm, material - plastics;
- the movement of a shaft in respect of the bushing from its initial position until it touches the vibrator's platform  $\Delta = 32$  mm;
- pressing force  $F$  varies from 45 N up to 105 N;
- oscillation amplitude  $A$  varies from 0.4 mm up to 3.0 mm;
- oscillation frequency  $f$  varies from 40 Hz up to 120 Hz.

During the experiment, a special attention was paid to the shaft slipping time measurement. The bushing begins to vibrate and the slipping time is begun to measure when the electrical switch connects the excitation circuit (Fig. 4).

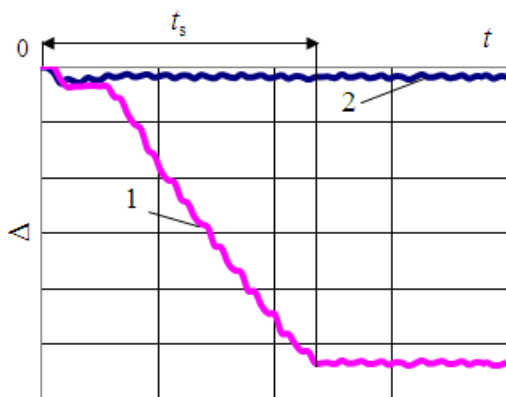

Fig. 4 The duration of shaft slipping:  $t_s$  – shaft slipping time until it touched the platform of electromagnetic vibrator; 1 - shaft's slip depth variation, when it moves in respect to the bushing; 2 - shaft's slip depth variation, when it does not move in respect to the bushing

When the pressing force exceeds the resistance force, then the shaft is moving in respect of the bushing until it touches the platform of the electromagnetic vibrator. Then it is vibrating together with the bushing in excited oscillation frequency and amplitude. However, not all tests end with a successful insertion of the shaft. In the

case when the pressing force was smaller than the resistance force, the shaft vibrates with the bushing, but does not move in respect of a bushing.

The shaft's movement was examined also without the use of vibrations, thus it would be possible to monitor the influence of vibrations of the same interference joints. Pressing force  $F$  was gradually increased until it resulted the complete shaft and bushing connection. The received data are displayed in Fig. 5.

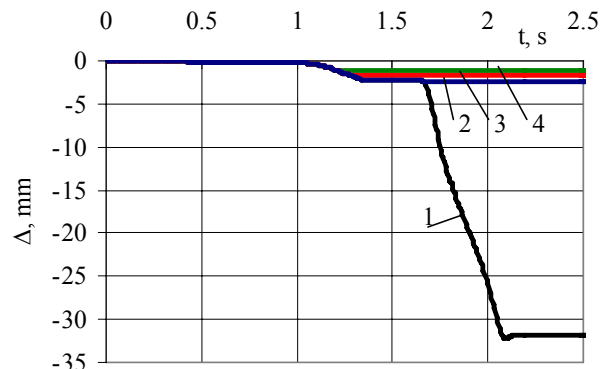

Fig. 5 Shaft's slip depth  $\Delta$  variation at different pressing forces. Pressing force: 1 - 105 N, 2 - 85 N, 3 - 65 N, 4 - 45 N

The shaft moved until the platform only when the pressing force was reaching 105 N. When the smaller force was applied on the shaft, then it was not moving in respect to the bushing. The shaft starts to move in the bushing only when the pressing force overcomes the resistance forces.

When vibration excitation was applied to the bushing, the shaft could be inserted fully with only 45 N compression force. In addition, it was found that changing the oscillation parameters, significantly influences the slipping duration of details. The insertion of the shaft takes less time with a higher frequency of oscillations (Fig. 6).

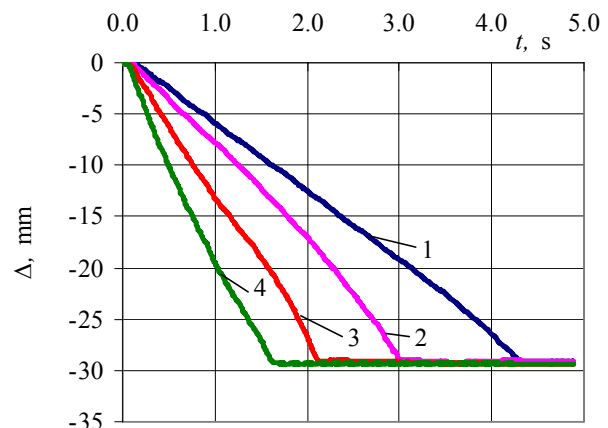

Fig. 6 Shaft's slip depth  $\Delta$  variation under different frequencies of vibrations  $f$ , when the amplitude  $A = 1.0$  mm. Frequency: 1 - 70 Hz; 2 - 80 Hz; 3 - 90 Hz; 4 - 100 Hz

The frequency range of vibrations at which the shaft is slipping in the bushing depends on the oscillation amplitude. When the pressing force is constant then bigger excitation amplitude require lower frequency range for inserting the shaft (Fig. 7).

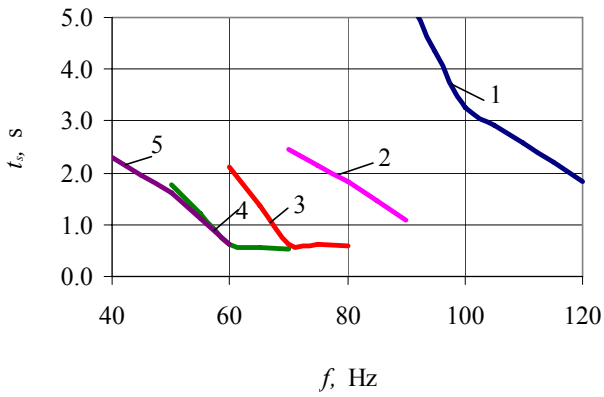

Fig. 7 The dependences of shaft slipping duration  $t_s$  with the frequency  $f$ , when the pressing force  $F = 45$  N. The amplitude of vibrations  $A$ : 1 - 0.6 mm; 2 - 1.2 mm; 3 - 1.8 mm; 4 - 2.4 mm; 5 - 3.0 mm

If oscillation amplitude is increasing, the duration of insertion decreases. This can be explained by higher velocity of movement of the shaft in the bushing and reduction of friction between the contacting surfaces. The range of oscillation amplitude, when the shaft is inserted in the bushing depends on the excitation frequency (Fig. 8).

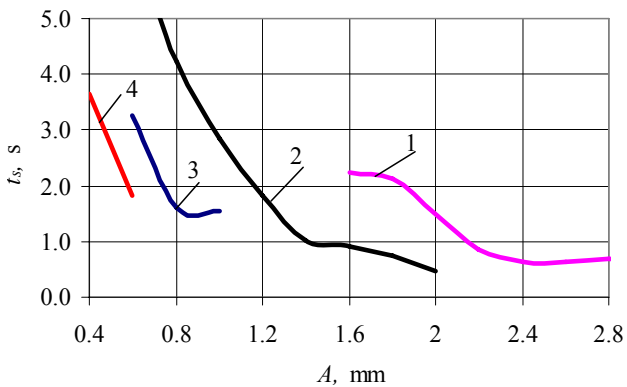

Fig. 8 The dependences of shaft slipping duration  $t_s$  on the amplitude of vibrations  $A$ , when the pressing force  $F = 45$  N. The frequency of vibrations  $f$ : 1 - 60 Hz; 2 - 80 Hz; 3 - 100 Hz; 4 - 120 Hz

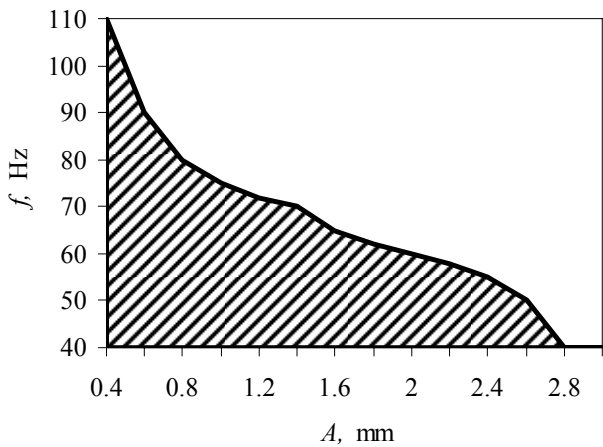

Fig. 9 The area of oscillation parameters  $f - A$  for reliable slipping until the platform (non-hatched). The pressing force  $F = 45$  N

It is possible to distinguish the values of amplitude when the slipping time  $t_s$  stops rapidly decreasing or is practically unchanged. If oscillation frequency is constant,

the increase of amplitude shortens the insertion time sharply until these values, but if the amplitude is increased further, then the insertion time is reduced in smaller proportions.

Combining excited oscillation frequency and amplitude values, the area of oscillation parameters when the shaft may be successfully inserted in the bushing is determined (Fig. 9).

When the shaft was pressed with 45 N force, the fastest insertion lasted 0.457 s and was observed under 2.0 mm amplitude and 80 Hz frequency vibrations. The slowest part connection was observed under 0.6 mm amplitude and 80 Hz frequency vibrations - 6.343 s.

When the pressing force  $F$  was increased from 45 to 65 N, the slipping time of the shaft was significantly reduced. Fastest insertion lasted 0.248 s under 2.0 mm amplitude, 80 Hz frequency excitation. The duration of the slowest insertion was recorded with 1.6 mm amplitude and 60 Hz - 1.314 s (Fig. 10).

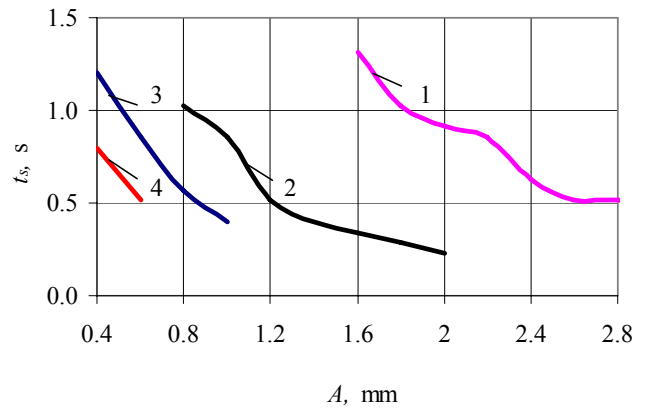

Fig. 10 The dependences of shaft slipping duration  $t_s$  on the amplitude of vibrations  $A$ , when the pressing force  $F = 65$  N. The frequency of vibrations  $f$ : 1 - 60 Hz; 2 - 80 Hz; 3 - 100 Hz; 4 - 120 Hz

The increase of oscillations amplitude has a smaller effect on decline of the connection time, if compared with pressing force 45 N. For example, when pressed with 45 N and oscillation frequency 80 Hz, then the increase of amplitude from 1.0 to 1.4 mm shortens the insertion time by 1.943 s, but same conditions with 65 N pressing force the insertion time drop is 0.457 s only.

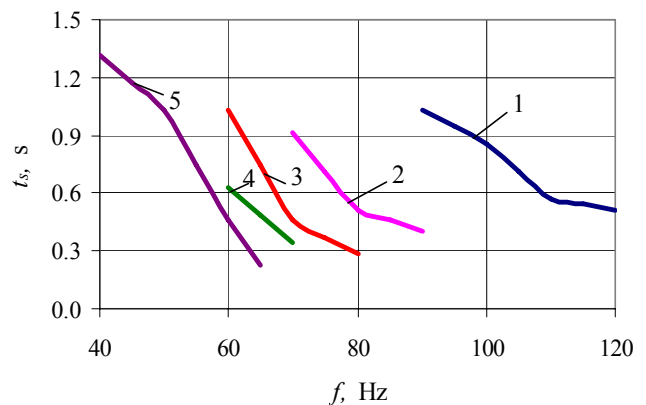

Fig. 11 The dependences of shaft slipping duration  $t_s$  on the frequency  $f$ , when the pressing force  $F = 65$  N. The amplitude of vibrations  $A$ : 1 - 0.6 mm; 2 - 1.2 mm; 3 - 1.8 mm; 4 - 2.4 mm; 5 - 3.0 mm

Shaft insertion time dependences on vibrational frequency at 65 N pressing force show that smaller amplitude vibrations require higher frequency range of oscillations (Fig. 11).

While increasing the pressing force, the successful insertion probability increases also and the shaft slips under wider oscillation frequency and amplitude range (Fig. 12).

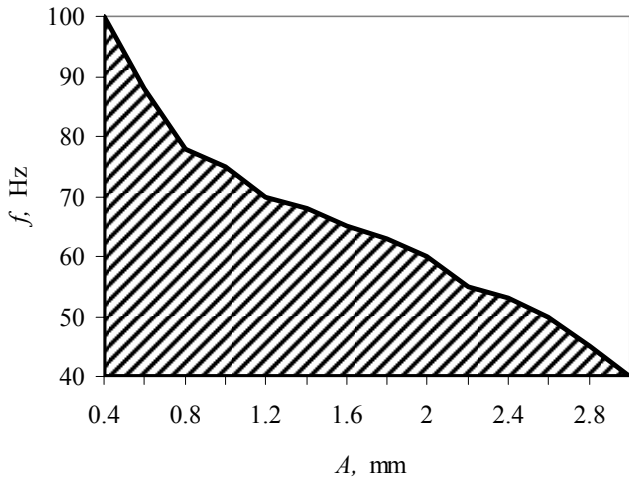

Fig. 12 The area of oscillation parameters  $f-A$  for reliable slipping until the platform (nonhatched). The pressing force  $F - 65$  N

When the pressing force was increased to 85 N, the slowest insertion did not exceed 1.205 s (1.4 mm amplitude, 60 Hz frequency) and shortest lasted 0.228 s (2.0 mm amplitude, 80 Hz) (Fig. 13).

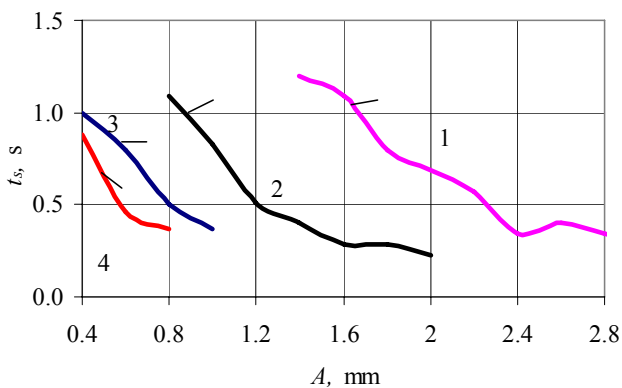

Fig. 13 The dependences of shaft slipping duration  $t_s$  on the amplitude of vibrations  $A$ , when the pressing force  $F - 85$  N. The frequency of vibrations  $f$ : 1 - 60 Hz; 2 - 80 Hz; 3 - 100 Hz; 4 - 120 Hz

When the pressing force  $F$  was increased from 65 to 85 N, the time of connection decreases, and the oscillation range suitable for connecting components increases (Figs. 14 and 15).

Reviewing the results it could be concluded that the fastest shaft insertion was performed, when the shaft was loaded an 85 N force and vibrating by 80 Hz, 2.0 mm amplitude - 0.228 s. The longest lasting insertion was observed when the shaft is acted by 45 N pressing force and the bushing is vibrating in 80 Hz, 0.6 mm amplitude oscillation and it took 6.343 s.

Further research tasks could be related with the

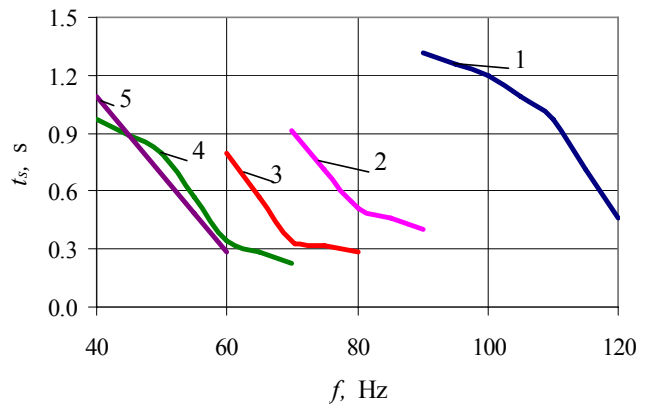

Fig. 14 The dependences of shaft slipping duration  $t_s$  on the frequency  $f$ , when the pressing force  $F - 85$  N. The amplitude of vibrations  $A$ : 1 - 0.6 mm; 2 - 1.2 mm; 3 - 1.8 mm; 4 - 2.4 mm; 5 - 3.0 mm

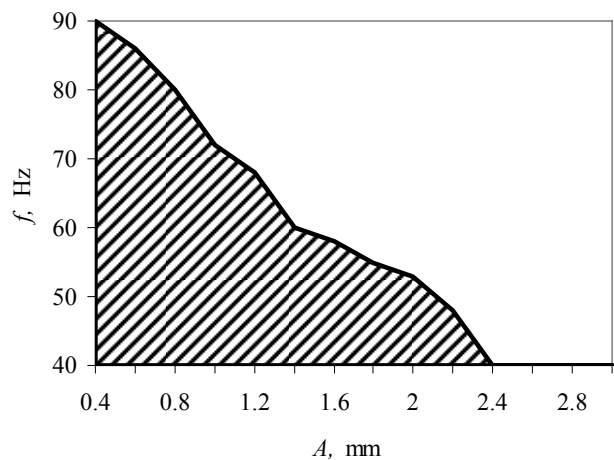

Fig. 15 The area of oscillation parameters  $f-A$  for reliable slipping until the platform (nonhatched). The pressing force  $F - 85$  N

influence of variation of interference and material of details to the process of shaft slipping in the bushing. It would also be interesting to investigate the characteristics of connection, when the details are excited by transverse vibrations.

#### 4. Conclusions

1. The experimental setup was mounted, that allows to monitor and analyze the slipping process of a shaft fastened with interference in a bushing, measure the insertion time, pressing force.

2. When the bushing is excited with the vibrations, it is possible significantly reduce the pressing force. Without the use of vibrations the shaft was inserted in the bushing while pressing force was 105 N and the insertion required only 45 N pressing force when the bushing was excited with vibrations.

3. While increasing the frequency of oscillations, the shaft insertion time is significantly reduced. Increasing the amplitude of vibrations also shortens the insertion time. When the bushing was vibrating by 80 Hz and 2.0 mm amplitude, the time for shaft insertion was shorter by 4 times, if compared with oscillation amplitude 0.8 mm.

4. Oscillation parameter areas were defined under different pressing forces for successful slipping of the shaft

until the platform of vibrator. The increase of pressing force allows reliable shaft slipping in a wider frequency and amplitude range.

## References

1. **Hamrock, B.J.; Schmid, S.R.; Jacobson, B.O.** 2005. Fundamentals of Machine Elements. McGraw-Hill Higher Education, 953p.
2. **Chowdhury, M.A.; Helali, Md.M.** 2006. The effect of frequency of vibration and humidity on the coefficient of friction, Tribology International 39: 958-962.
3. **Kumar, V.C.; Hutchings, I.M.** 2004. Reduction of the sliding friction of metals by the application of longitudinal or transverse ultrasonic vibration, Tribology International 37: 833-840.
4. **Bakšys, B.; Kilikevičius, S.** 2006. Insertion investigation of cylindrical parts to be assembled with clearance, Mechanika 2(58): 30-39.
5. **Vybiral, D.; Augustynek, M.; Penhaker M.** 2011. Devices for position detection. Vibroengineering. Volume 13, issue 3: 531-535.
6. **Manninen, T.; Kanervo, K.; Revuelta, A.; Larkiola, J.; Korhonen, A.S.** 2007. Plastic deformation of solderless press-fit connectors, Materials Science and Engineering; 633-637.
7. **Rimkevičienė, J.; Ostaševičius, V.; Jūrėnas, V.; Gaidys, R.** 2009. Experiments and simulations of ultrasonically assisted turning tool, Mechanika 1(75): 42-46.

B. Bakšys, J. Mikolainis

## EKSPERIMENTINIS ĮVORĖJE ĮVERŽTO VELENO VIBRACINIO SLYDIMO TYRIMAS

### R e z i u m ė

Straipsnyje nagrinėjamas įvorėje įveržto veleno vibracinio slydimo procesas, kai velenas yra veikiamas ašinės jėgos, o įvorė žadinama ašine kryptimi. Sumontuotas eksperimentinis stendas, kuriuo naudojantis nustatytas su įvarža įvorėje įstatyto veleno slydimo iki atramos charakteristikos. Pateiktas veleno įstatymo gylio kitimo, nežadinant įvorės ir ją žadinant skirtingo dažnio virpesiais, grafikas. Sudarytos veleno įstatymo trukmės priklausomybės nuo žadinimo dažnio ir amplitudės esant skirtingoms ašinėms jėgoms. Nustatytos įvorės virpesių parametru derinių zonos, kai velenas patikimai įstatomas nustatytu gyliu. Išsiaiškinta, kad įvorę žadinant ašine kryptimi galima gerokai sumažinti presavimo jėgą, o veleno įstatymo trukmė priklauso nuo žadinimo dažnio ir amplitudės.

B. Bakšys, J. Mikolainis

## EXPERIMENTAL RESEARCH OF VIBRATORY SLIPPING OF THE SHAFT FASTENED WITH TIGHTNESS IN THE BUSHING

### S u m m a r y

The paper deals with the process of vibratory slipping of the shaft fastened in the bushing, when the shaft is acted by axial force and the bushing is excited in axial direction. The experimental setup was mounted for determining the characteristics of shaft slipping. The graph of shaft insertion depth is given without excitation of the bushing and exciting it with different frequency vibrations. The dependences of shaft insertion duration on oscillation frequency and amplitude with different pressing forces are provided. It was found that when the bushing is excited in axial direction, the pressing force may be significantly reduced. Shaft insertion time depends on the excitation frequency and amplitude.

Received February 21, 2011

Accepted October 21, 2011